



INVOLUTE TOOLING CORPORATION

MANUFACTURERS OF DRIVES AND TRANSMISSIONS

OFFICE: 13, JORBAGH, NEW DELHI - 110 003, INDIA, TEL: +91(011)24621453 FAX: +91(011) 24603609
WORKS: PLOT-65, SEC-27C, FARIDABAD - 121 003. INDIA, TEL: +91(0129) 4279000, 4279001
EMAIL : involute@vsnl.com URL: www.involutetools.com/ www.gears-reducers.com



FEATURES

- The rigid, vibration-damping housing of close grained cast iron enables to take up & transmit safely all forces & loads.
- Maximum thermal efficiency is ensured by a large oil reservoir. Splash lubrication ensures ample and positive oil flow to all gears and bearings.
- To ensure correct tooth contact, parallelism of bearing bores are maintained with precise tolerance.
- High efficiency of over 98% per stage of reduction achieved when loaded to full capacity of the units. The precision gearing and accuracy of bearing alignment preserves this high efficiency.
- Shafts of carbon steel are machined to high precision tolerance to ensure concentricity of bearing seats with gear teeth.
- The gear teeth are precision cut to involute shape, designed to give maximum tooth contact and overlap.
- Anti-friction type bearings are used throughout to ensure high efficiency and for maintaining the precision tolerance required between the gear centres.
- Positive seals prevent oil leakage at both high speed and low speed shafts.



SPECIFICATIONS

HOUSINGS - Housings are of cast iron, generously proportioned to ensure proper radiation of heat generated when Units are operated at their maximum capacity. Suitable ribs are placed underneath the bearing seats for strength and the walls are of sufficient thickness to withstand the most severe stresses encountered during operation.

GEARS AND PINIONS - The Gears are generated with highest accuracy on Hobbing Machine. The materials for the Pinion and Gear Wheel or Gear Wheel Rim are made of hard wearing special steel of graded strength to meet the individual load conditions. The selection of module, tooth profile and helix angle is made in conformity with speeds, ratios and load conditions to give maximum tooth contact and overlap, thus ensuring most favourable meshing and silent running.

SHAFTS - Shafts having Pinions cut integral are of heat treated alloy steel bar or alloy steel forging. All other shafts are of heat treated Carbon Steel and are finished to high precision tolerance by grinding.

BEARINGS - Anti-friction bearings of ample size are used throughout to ensure long service life. The use of anti-friction bearings ensures high efficiency, correct centre distance and proper shaft alignment. In case of extra over-hung loads due to pulley, pinion etc. on Shafts, reinforced extra heavy bearings are used. Oil Seals on both high speed and low speed shafts prevent oil leakage and provide protection for the bearings from dust and dirt.

LUBRICATION - For normal speeds, splash lubrication is provided by the gears dipping in oil. Oil reservoir is of ample size to ensure cool operation. The oil level indicator located in the housing is to ensure a proper amount of lubricant in the housing. Wherever splash lubrication is not effective to carry oil to gears and bearings, a built-in or separately mounted lubrication oil pump is used for forced-feed lubrication.

COOLING - The heat generated within the gear units is dissipated by a sufficiently large surface area of the housing. For higher capacities the units are provided with cooling coils in the lower part of the housing for allowing cool water passing through a coil through a suitable port entry. With pressure lubrication, an oil cooler can be mounted in the oil circuit to achieve more efficient and effective cooling.

EFFICIENCY - Efficiency of approximately 98% are obtained in the Single Reduction Units, 96% in the Double Reduction Units and 94% in the Triple Reduction Units.

REDUCTION RATIOS - Single Reduction Units from 1.8:1 to 8:1, Double Reduction Units from 8:1 to 48:1 and Triple Reduction Units from 10:1 to 160:1 can be supplied. Ratios not shown in the catalogue can also be provided on special request.

DESIGN

- The gear units are specially designed for crane duty applications in accordance with IS:3177
- Horizontal gear units comprise of helical gears whereas in vertical gear units, the reduction is through spur gearing.
- All pinions are integral with the shafts. Materials for gears are forged from high grade carbon or alloy steel.
- Gears teeth are cut with metric module system in accordance with relevant standard specifications.
- The gear units are rated in accordance with IS:4460
- The housings are of cast iron and machined with close tolerance to ensure perfect alignment of gears.
- Anti-friction bearings are used to ensure long service life and high efficiency.



TYPE OF OIL

The lubricating oil used should be straight mineral oil or Extreme Pressure (E.P.) oil as specified below. Straight mineral oil should be high graded well refined petroleum oil within the recommended viscosity range. It must be neutral in viscosity; no grit or abrasives should be present. For high operating temperatures; good resistance to oxidation is needed. Units those are subjected to heavy shock load or extremely heavy duty should have extreme pressure (E.P.) lubricant.

TEMPERATURE

Abnormal conditions of ambient temperature should be referred to us for recommendation of suitable lubricant.

OIL CHANGES

After mounting the Gear Unit it should be filled in with recommended lubricating oil through the inspection hole. The first oil change should be made after about 500 hours running or two months whichever is earlier. The subsequent changes would be made every 2000 hours or one year whichever is earlier. Oil should be drained off and the gear case should be thoroughly flushed with light flushing oil. From time to time the oil level inside the Gear Box should be checked and this should be maintained upto the recommended level. The operating temperature should not be excessive. Temperature upto 90°C is harmless to any component.

RECOMMENDED LUBRICANTS

MAKER'S NAME	R. P. M. OF HIGH SPEED SHAFT				
	WITHOUT OIL PUMP		WITH OIL PUMP		
	Upto 250	250-1500	Upto 250	250-1500	Above 1500
INDIAN OIL	Servomesh SP 257	Servomesh SP 150	Servomesh SP 150	Servomesh SP 150	Servomesh SP 68
CASTROL	Alpha SP 320	Alpha SP 220	Alpha SP 220	Alpha SP 150	Alpha SP 68
BHARAT PETROLEUM	Bharat Amocam 220	Bharat Amocam 150	Bharat Amocam 150	Bharat Amocam 150	Bharat Amocam 100
HINDUSTAN PETROLEUM	Parthan EP 220	Parthan EP 150	Parthan EP 150	Parthan EP 150	Parthan EP 100
BALMER LAWRIE	Balmerol Gear Flux BM 257	Balmerol Gear Flux BM 150	Balmerol Gear Flux BM 150	Balmerol Gear Flux BM 150	Balmerol Gear Flux BM 68

When gear unit additionally warmed up by radiant heat, use oil of next higher viscosity.
For input H.P. more than 100, use oil of next higher viscosity.



SELECTION PROCEDURE OF GEAR UNITS

Satisfactory performance of the gearbox depends upon correct selection. The selection of a gear unit is influenced by the class of duty of the crane which should be determined and specified. Single, Double and Triple stage Horizontal gear units type HA, HB and HC are recommended for Hoist and Long Travel drive. Three stage vertical gear units type VC are recommended for cross travel drives of the EOT crane. Assembly arrangement must be specified while ordering the gear units.

SELECTION PROCEDURE

1. Compute the required reduction ratio.
2. Determine the horsepower required for the prime mover.
3. Refer to the rating table, see in the ratio column and based on input rpm check the gear box rating horizontally for various class of duty of the crane.
4. The size should be selected such that the rated HP is equal or more than the consumed HP.

EXAMPLE

1. Select a unit to transmit 9 HP from 720 rpm electric motor for hoist drive in a class II duty crane, the reduction ratio required is 31.50.
 - For hoist drive a two stage horizontal gearbox type HB will be suitable.
 - See the ratio column and in the size HB-350, for input rpm of 720 in class II duty the rated HP is 9.5
 - As the consumed HP is 9, the unit HB-350 will be suitable.
2. Select a unit to transmit 3 HP from 960 rpm electric motor for cross travel drive in a class IV duty crane, the reduction ratio required is 14.26.
 - For cross travel drive, a vertical gearbox type VC will be suitable.
 - See the ratio column and in the size VC - 320, for input rpm of 960 in class IV duty the rated HP is 3
 - As the consumed HP is 3, the unit VC - 320 will be suitable.

SPECIAL FEATURES

- The gear units can also be supplied for heavy duty EOT cranes for use in steel works in accordance with IS:4137
- The input shafts can be supplied as tapered.
- Output Shaft can be supplied with integral toothed male clutch.
- The gear units can also be supplied with fabricated & stress-relieved housing.
- The gear units are available with various assembly arrangements such as,

S, U, K, Z, Y, P, M, N and H

ARRANGEMENT

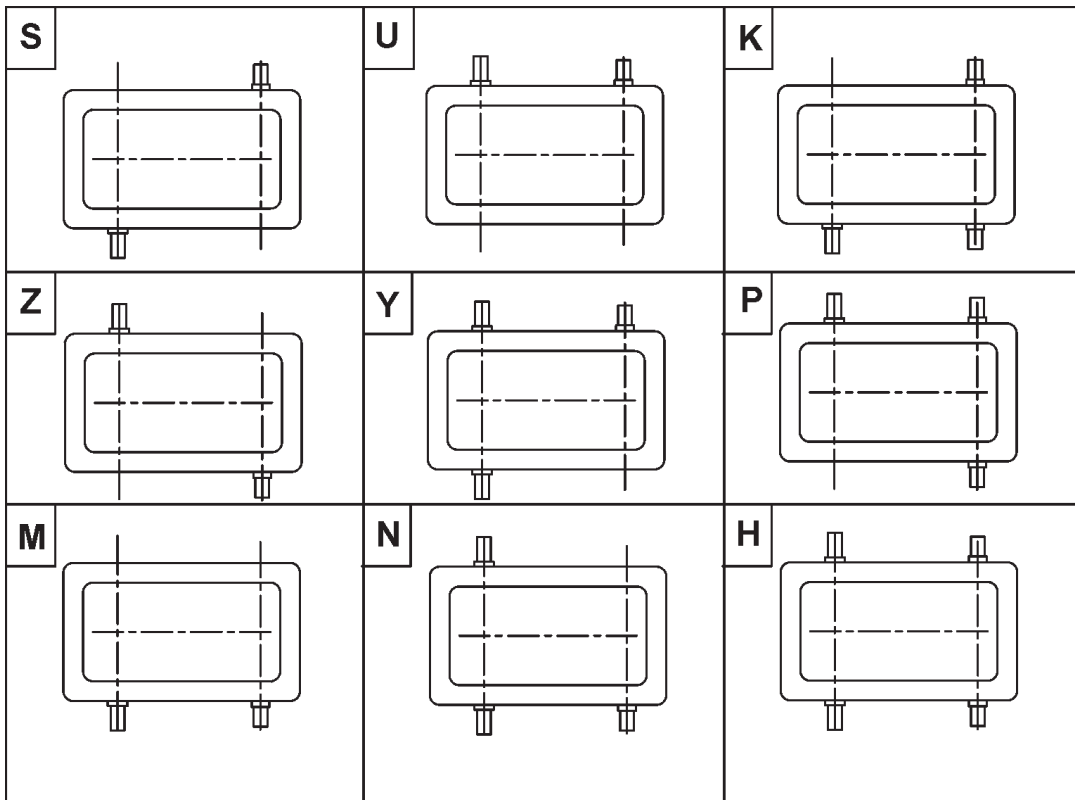

OUTPUT SHAFT WITH INTEGRAL TOOTHED MALE CLUTCH

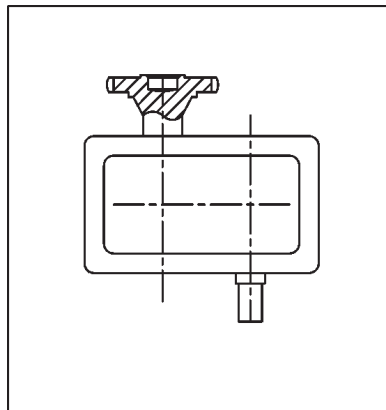

PRINCIPAL TYPES

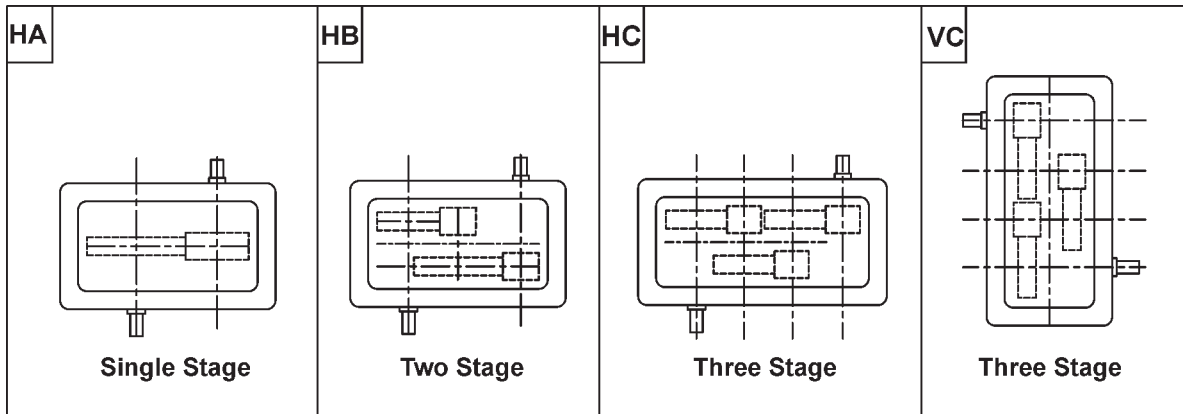

SINGLE STAGE

HORIZONTAL TYPE 'HA'

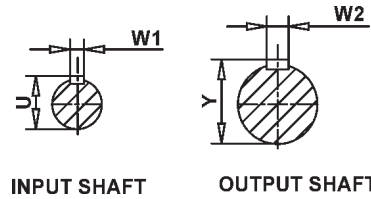
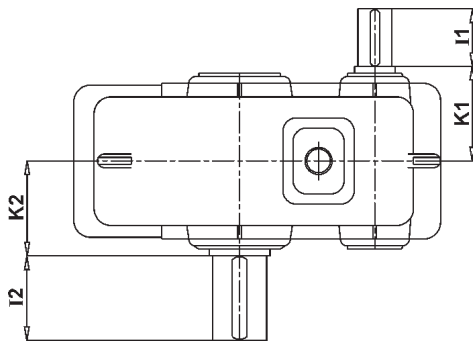
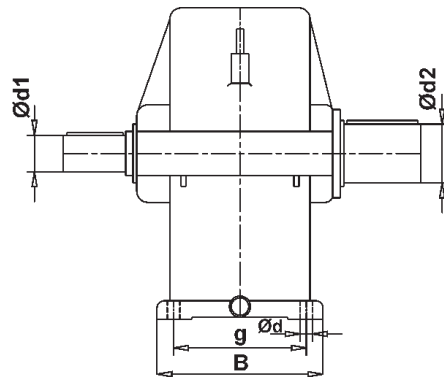
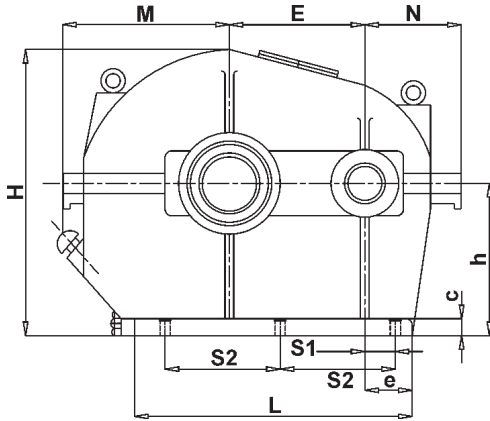

PRINCIPAL DIMENSIONS in mm

SIZE	Housing dimension								Foundation hole details						Weight (Approx. kg)	
	HA	E	e	L	B	H	h	N	M	S ₁	S ₂	g	d	c		No.
100	100	52	260	154	233	125	95	-	-	30	170	115	15	18	4	39
150	150	60	330	190	323	170	115	225	225	35	230	150	17	22	4	80
200	200	70	410	225	423	225	142	275	275	45	300	180	17	25	4	136
250	250	75	505	300	515	265	165	330	330	45	190	230	25	25	6	250
300	300	75	580	330	610	315	190	420	420	45	230	260	25	30	6	327
350	350	95	695	385	697	355	220	465	465	55	280	315	32	35	6	610
400	400	150	870	400	792	400	253	500	500	110	350	320	32	35	6	820

Size	INPUT SHAFT			OUTPUT SHAFT			INPUT KEY		OUTPUT KEY	
HA	d ₁	l ₁	K ₁	d ₂	l ₂	K ₂	W ₁	U	W ₁	Y
100	30	60	82	35	55	92	8	33	10	38
150	40	85	100	55	85	115	12	43	16	59
200	50	85	155	80	120	125	14	53.5	22	85
250	60	108	205	80	120	160	18	64	22	85
300	60	108	220	80	120	175	18	64	22	85
350	90	135	242	110	145	228	25	95	28	116
400	90	135	250	110	145	235	25	95	28	116



H.P. Rating for Single Stage Horizontal Gear Boxes Type HA

SIZE	HA-100								HA-150								HA-200							
RPM	960				720				960				720				960				720			
Duty Ratio	I	II	III	IV	I	II	III	IV	I	II	III	IV	I	II	III	IV	I	II	III	IV	I	II	III	IV
1.83	24.6	17.6	13.5	10.8	19.2	13.6	10.6	8.45	81.8	59	45.5	36.4	64.8	46	36.6	28.5	178	126	98	78	139	100	76.5	61
2.3	21.3	15.1	11.7	9.35	17.0	12.1	9.35	7.5	71.5	50.7	39.4	31.4	56.7	40.5	31.2	25	158	112	87	69.5	125	89	69	55
2.81	18	12.8	9.9	7.9	14.5	10.8	8.2	6.8	60.5	43	33.3	26.6	48.8	36	27.3	22.9	135	96	74	59.5	109	79.5	62	50
3.5	15.6	11.1	8.6	6.85	12.8	9.1	7.05	5.6	52.7	37.4	29	23.2	43.2	30.6	23.7	19	120	85	66	52.5	98	70	54	43
3.95	14.2	9.9	7.82	6.25	11.2	8	6.15	4.9	46.5	32.2	25.6	20.4	36.2	26	20	16	110	76.5	60.7	48.5	86	61	47.5	38
4.5	12.6	9.15	7.05	5.5	9.9	7.2	5.5	4.35	42.2	30.6	23.6	18.3	33	24	18.5	14.6	99	71.5	55.5	43	78	57	43.7	35.4
5.6	10.2	7.1	5.4	4.44	8.4	5.95	4.6	3.8	34.4	23.9	18.3	15.3	28.2	20	15.4	12.7	81.5	56.6	43.3	36.2	67	47.5	36.6	30.2
6.615	8.26	5.75	4.4	3.6	6.7	4.7	3.66	3.02	27.9	19.4	14.8	12.4	22.8	16.2	12.5	10.3	66.1	47	35.2	29.4	54	38.4	29.5	24.3
8.0	6.7	4.65	3.56	2.92	5.4	3.84	2.95	2.44	22.4	15	11.9	10	18.4	13.1	10.1	8.3	53	35.4	28.2	23.6	43.5	30.8	23.8	19.6

SIZE	HA-250								HA-300								HA-350							
RPM	960				720				960				720				960				720			
Duty Ratio	I	II	III	IV	I	II	III	IV	I	II	III	IV	I	II	III	IV	I	II	III	IV	I	II	III	IV
1.83	346	246	190	152	270	192	151	119	664	470	364	292	520	370	286	229	1050	735	575	460	820	580	450	360
2.3	308	218	169	135	244	173	134	107	572	405	314	252	453	322	250	199	910	645	500	400	720	512	396	317
2.81	260	184	143	114	210	153	120	98.5	485	344	266	214	392	286	223	172	768	545	423	337	620	452	352	272
3.5	235	167	130	104	192	136	105	84	420	300	231	185	344	244	189	151	667	465	367	294	545	386	300	240
3.95	218	153	120	96	170	121	93.5	75	374	260	207	165	290	206	160	130	605	420	334	266	470	334	260	206
4.5	193	140	108	84	150	109	84	69	336	243	188	146	262	191	145	118	530	384	297	231	414	302	232	186
5.6	159	111	85.5	69	130	92.2	70.8	58.5	275	191	146	120	226	160	123	102	437	304	232	190	358	254	195	161
6.615	129	89.6	69.5	56	105	74.5	57.2	47.2	223	155	118.5	97	182	129	99	82	354	246	188	154	290	206	158	131
8.0	102	71	54.2	44.4	83.5	58.5	45.5	37.5	179	124	95.5	77.7	147	104	80	66	262	182	139	114	214	152	117	96

SIZE	HA-400							
RPM	960				720			
Duty Ratio	I	II	III	IV	I	II	III	IV
1.83	1570	1020	865	690	1225	870	673	538
2.3	1360	965	745	597	1080	765	595	475
2.81	1142	810	628	502	920	670	523	405
3.5	1000	715	552	440	818	580	450	360
3.95	909	630	502	400	710	505	390	312
4.5	810	585	455	352	630	460	352	277
5.6	652	454	346	283	535	380	292	240
6.615	528	368	280	230	433	308	236	195
8.0	390	271	207	170	320	227	174	144

DOUBLE STAGE
HORIZONTAL TYPE 'HB'

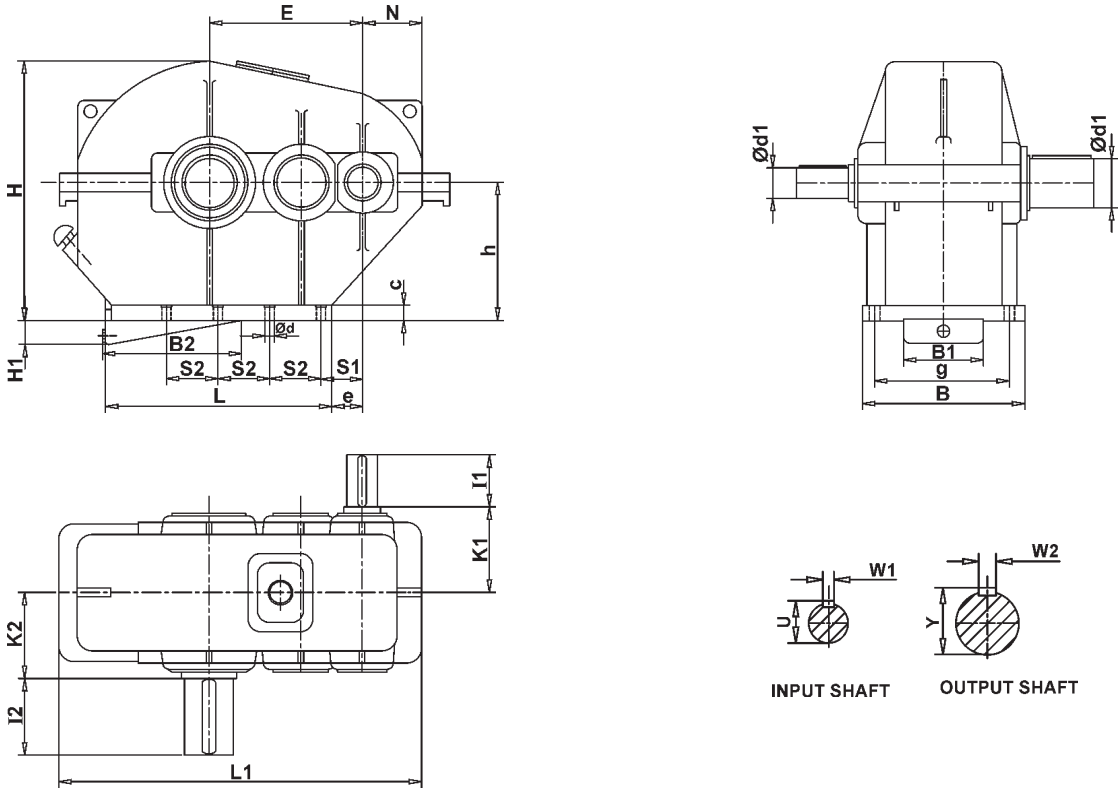

PRINCIPAL DIMENSIONS in mm

SIZE	Housing dimension										Foundation hole details							Weight (Approx kg)
HB	E	e	L	B	H	h	N	L ₁	B ₁	B ₂	H ₁	S ₁	S ₂	g	d	c	No.	
250	250	28	300	230	320	160	111	555	-	-	-	60	236	190	18	20	4	102
350	350	60	415	290	393	200	123	710	-	-	-	100	310	250	18	20	4	172
400	400	80	490	310	505	250	140	826	-	-	-	110	370	270	18	25	4	275
500	500	80	620	360	591	300	150	985	-	-	-	130	240	310	18	25	6	400
650	650	75	840	470	716	320	200	1300	326	500	99	160	215	410	28	33	8	970
750	750	55	1025	510	745	320	207	1410	352	620	130	155	275	450	28	35	8	1130
850	850	75	1105	570	880	400	240	1640	416	640	105	155	300	510	33	38	8	1662
1000	1000	100	1350	660	972	400	257	1896	486	870	200	200	350	590	33	38	8	2840

Size	Input Shaft			Output Shaft			Input Key		Output Key	
HB	d ₁	I ₁	K ₁	d ₂	I ₂	K ₂	W ₁	U	W ₂	Y
250	30	60	145	55	85	150	8	33	16	59
350	38	85	170	55	85	175	10	41	16	59
400	38	85	185	80	125	190	10	41	22	85
500	48	85	210	80	125	215	14	51.5	22	85
650	55	110	275	110	165	285	16	59	28	116
750	60	110	310	120	165	335	18	64	32	127
850	85	130	325	130	200	335	22	90	32	137
1000	85	140	380	170	240	390	22	90	40	179



H.P. Rating for Double Stage Horizontal Gear Boxes Type HB

SIZE	HB-250								HB-350								HB-400							
RPM	960				720				960				720				960				720			
Duty Ratio	I	II	III	IV	I	II	III	IV	I	II	III	IV	I	II	III	IV	I	II	III	IV	I	II	III	IV
8.23	24.4	17	12.7	9.5	19	12.7	10.6	7.4	55.5	39	30.4	21	43	30.4	24.2	16.8	75	54	41.5	33	60.5	42.5	34	26.5
10.35	20.1	13.8	10.6	7.4	16	10.6	8.5	6.35	46	32.6	25.2	16.8	37	25.2	20	13.7	66	45.5	37	28.6	53	37	29.6	22.2
12.64	17	11.7	9.6	6.4	13.8	9.5	7.4	5.3	39	27.4	21	14.7	31.5	22	16.8	11.6	57.2	39.2	31.8	24.4	46.5	31.8	25.4	19.1
15.74	14.9	9.5	8.5	5.3	10.6	7.4	6.4	4.3	33.6	23.1	17.9	12.6	25.2	17.9	13.7	9.5	49.8	34	26.5	19.1	39.2	26.5	21.2	14.8
20.49	11.7	8.5	6.4	4.3	8.5	6.4	4.3	3.2	26.3	18.9	13.7	9.5	21	14.7	10.5	7.4	44.5	30.8	24.4	17	35	24.4	19.1	12.7
23.34	9.6	7.4	5.3	3.2	7.4	5.3	4.3	3.2	23.1	16.8	12.6	8.4	18.9	12.6	9.5	6.3	39	27	21.2	14.8	32	21.2	17	11.7
31.50	7.4	5.3	4.3	3.2	6.4	4.3	3.2	2.1	17.8	12.6	9.5	6.3	13.7	9.5	7.4	5.3	30.4	22	14.7	10.6	23.2	17	11.7	8.5
40.17	6.4	4.3	3.2	2.1	4.3	3.2	2.1	2.1	14.7	10.5	7.4	5.3	10.5	7.4	5.3	4.3	25.5	18	12.7	8.5	21.2	14.7	9.5	7.4
48.57	5.3	3.2	2.1	2.1	4.3	2.1	2.1	1.1	12.6	8.4	6.3	4.3	9.5	6.3	4.3	3.2	23.4	15.9	10.6	7.4	18	11.7	8.5	5.3

SIZE	HB-500								HB-650								HB-750							
RPM	960				720				960				720				960				720			
Duty Ratio	I	II	III	IV	I	II	III	IV	I	II	III	IV	I	II	III	IV	I	II	III	IV	I	II	III	IV
8.23	184	126	96	65	147	102	75.5	52	358	252	196	143	274	201	160	113	610	435	302	204	485	340	250	161
10.35	153	107	76.5	52.5	124	86	62	41	306	210	171	118	244	170	135	92	510	356	238	165	410	284	193	152
12.64	129	92	64	43.5	104	71	51	35	263	181	144	96	208	145	114	77	432	306	203	136	342	238	159	109
15.74	111	76	49	34	84	59	42	29	221	150	118	78	175	120	93	62	370	255	167	116	279	197	134	93
20.49	78	55	37	25	62	43	29	20	199	136	90	60	156	108	71	49	292	195	129	85	228	155	100	69
23.34	72	50	34	23.5	57	40	27	18.5	181	123	81	54	142	97	63	44	264	176	119	78	208	140	90	63
31.50	61	42	29	20	47	34	23	16	138	95	62	42	108	77	49	34	206	142	92	63	159	111	74	51
40.17	48	34	22	15	37	25	17	11.6	113	78	48	34	88	61	38	26	163	109	68	48	125	86	53	38
48.57	41	28.5	18	13	31.5	22	14	9.5	95	65	41	28.5	73	49	31.5	22	135	92	58	41	104	74	44	32

SIZE	HB-850								HB-1000							
RPM	960				720				960				720			
Duty Ratio	I	II	III	IV	I	II	III	IV	I	II	III	IV	I	II	III	IV
8.23	1025	702	468	330	815	570	413	285	2050	1367	1050	739	1630	1086	835	588
10.35	857	587	391	270	689	478	319	220	1714	1142	878	622	1378	918	706	493
12.64	726	497	331	233	574	395	255	180	1452	968	691	490	1148	765	546	382
15.74	622	426	284	200	469	323	215	153	1244	802	572	402	938	625	446	314
20.49	426	292	195	139	333	228	152	108	852	591	422	297	666	475	339	240
23.34	385	269	179	128	304	211	136	97	770	531	379	267	608	419	299	210
31.50	301	206	137	98	232	159	106	76	602	415	296	208	462	318	220	155
40.17	238	163	109	79	182	125	83	60	476	328	234	165	366	250	173	119
48.57	197	135	90	65	152	104	69	50	394	271	193	136	307	211	146	102

TRIPLE STAGE
HORIZONTAL TYPE 'HC'

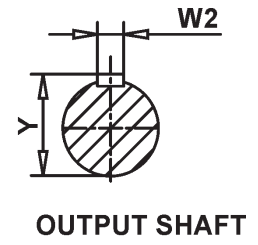
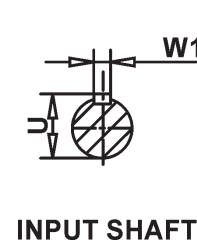
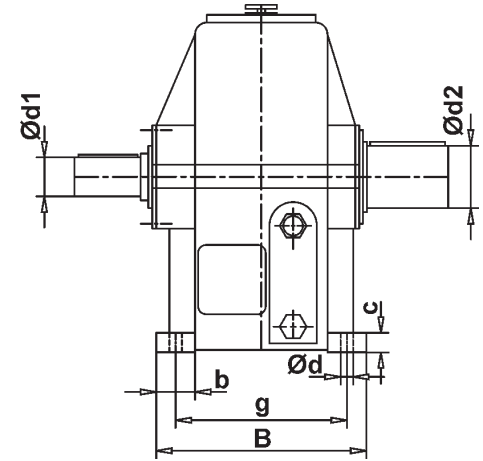
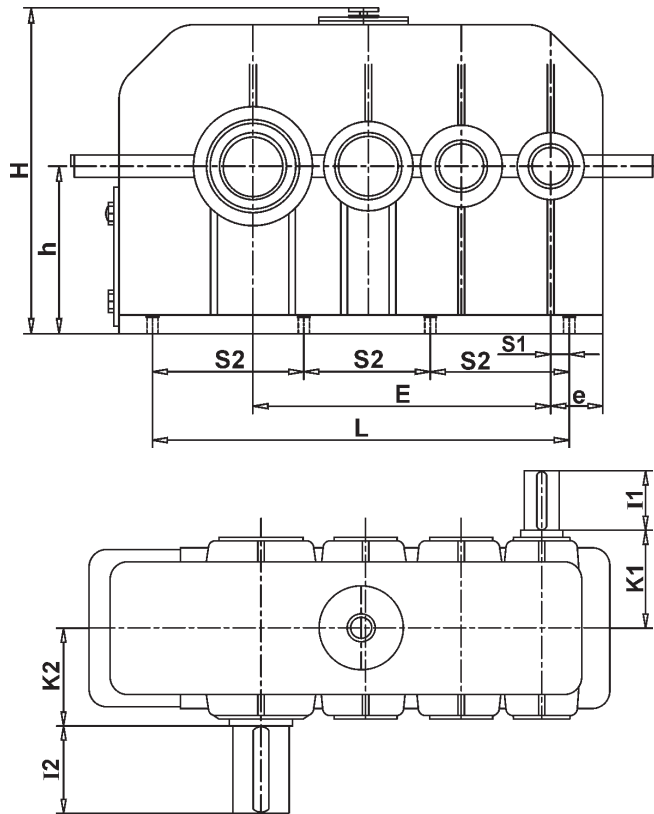

PRINCIPAL DIMENSIONS in mm

SIZE	Housing dimension								Foundation hole details					Weight (approx.) kg
	E	e	L	B	b	H	h	s ₁	s ₂	g	d	c	No.	
400	400	70	650	270	50	415	200	45	280	225	16	23	6	260
450	450	80	730	300	52.5	460	225	50	315	250	16	25	6	360
500	500	95	820	330	55	510	250	55	355	280	18	27	6	470
560	560	110	920	370	60	565	280	40	280	315	20	30	8	620
630	630	120	1030	415	70	630	315	42.5	315	355	23	34	8	850
710	710	130	1160	470	80	705	355	47.5	355	400	25	37	8	1150
800	800	140	1300	530	90	800	400	50	400	450	27	40	8	1580
900	900	160	1460	590	100	895	450	55	450	500	30	42	8	2050
1000	1000	180	1620	650	110	995	500	60	500	560	33	45	8	2650
1120	1120	200	1820	730	120	1105	560	70	560	630	36	48	8	3500
1250	1250	230	2040	830	140	1235	630	75	630	710	39	52	8	4700

Size	Input Shaft			Output Shaft			Input Key		Output Key	
	d ₁	I ₁	K ₁	d ₂	I ₂	K ₂	W ₁	U	w ₂	Y
400	28	40	155	70	105	160	8	31	20	74.5
450	32	45	170	70	115	180	10	35	20	74.5
500	38	50	185	85	130	195	10	41	22	90
560	45	60	210	95	145	215	14	48.5	25	100
630	50	65	225	105	160	235	14	53.5	28	111
710	55	75	260	120	180	270	16	59	32	127
800	55	80	290	125	200	300	16	59	32	132
900	65	100	320	140	225	330	18	69	36	148
1000	70	105	350	170	250	365	20	74.5	40	179
1120	75	115	400	190	280	440	20	79.5	45	200
1250	80	120	415	200	300	460	22	85	45	210



H.P. Rating for Triple Stage Horizontal Gear Boxes Type HC

SIZE	HC-400								HC-450								HC-500							
	960				720				960				720				960				720			
	Duty Ratio	I	II	III	IV	I	II	III	IV	I	II	III	IV	I	II	III	IV	I	II	III	IV	I	II	III
31.5	16.8	12.1	9.9	7.2	13.1	9.4	7.7	5.6	24	17.2	14.2	10.3	18.7	13.4	11	8	33	23.7	19.5	14.2	25.7	18.5	15.2	11.1
40	13.9	10	8.2	6	10.8	7.8	6.4	4.6	19.7	14.1	11.6	8.5	15.4	11.1	9.1	6.6	27.6	19.8	16.3	11.9	21.5	15.4	12.7	9.2
50	11.5	8.3	6.8	4.9	9	6.5	5.3	3.9	16.3	11.7	9.6	7	12.7	9.1	7.5	5.5	22.8	16.4	13.5	9.8	17.8	12.8	10.6	7.7
63	9.6	6.9	5.7	4.1	7.5	5.4	4.4	3.2	13.7	9.8	8.1	5.9	10.7	7.7	6.3	4.6	18.4	13.2	10.9	7.8	14.4	10.3	8.5	6.2
80	7.7	5.5	4.5	3.3	6	4.3	3.5	2.6	11	7.9	6.5	4.7	8.6	6.2	5.1	3.7	15.2	10.9	9	6.5	11.9	8.5	7	5.1
90	7	5	4.1	3	5.5	3.9	3.2	2.3	9.8	7	5.8	4.2	7.6	5.5	4.5	3.3	13.8	9.9	8.1	5.9	10.8	7.8	6.4	4.6
100	6.2	4.4	3.7	2.7	4.8	3.4	2.8	2.1	8.9	6.4	5.3	3.8	6.9	5	4.1	3	12.3	8.8	7.3	5.3	9.6	6.9	5.7	4.1
125	5.1	3.7	3	2.2	4	2.9	2.4	1.7	7.2	5.2	4.2	3.1	5.7	4.1	3.4	2.5	10.2	7.3	6	4.4	8	5.7	4.7	3.4
160	4.1	2.9	2.4	1.8	3.2	2.3	1.9	1.4	5.8	4.2	3.4	2.5	4.5	3.2	2.7	1.9	8	5.7	4.7	3.4	6.3	4.5	3.7	2.7

SIZE	HC-560								HC-630								HC-710							
	960				720				960				720				960				720			
	Duty Ratio	I	II	III	IV	I	II	III	IV	I	II	III	IV	I	II	III	IV	I	II	III	IV	I	II	III
31.5	46.8	33.6	27.6	20.1	37	26.6	21.8	15.9	66	47.4	38.9	28.4	52	37.3	30	22.4	95	68.2	56	40.9	74	53.1	43.7	31.8
40	39	28	23	16.8	30.8	22.1	18.2	13.2	56	40.2	33	24.1	44.2	31.7	26	19	78	56	46	33.5	60.5	43.4	35.7	26
50	32.2	23.1	19	13.8	25.4	18.2	15	10.9	46	33	27.1	19.8	36.3	26.1	21.4	15.6	65	46.7	38.4	28	50.4	36.2	29.7	21.7
63	26.4	19	15.6	11.4	20.9	15	12.3	9	38	27.3	22.4	16.3	30	21.5	17.7	12.9	54	38.8	31.9	23.2	42	30.2	24.8	18.1
80	21.4	15.4	12.6	9.2	16.9	12.1	10	7.3	31	22.3	18.2	13.3	24.5	17.6	14.4	10.5	44	31.6	26	18.9	34.1	24.5	20.1	14.7
90	19.5	14	11.5	8.4	15.4	11.1	9.1	6.6	27	19.4	15.9	11.6	21.3	15.3	12.6	9.2	39	28	23	16.8	30.3	21.8	17.9	13
100	17.6	12.6	10.4	7.6	13.9	10	8.2	6	25	18	14.8	10.8	19.8	14.2	11.7	8.5	35	25.1	20.7	15.1	27.2	19.5	16	11.7
125	14.2	10.2	8.4	6.1	11.2	8	6.6	4.8	20.5	14.7	12.7	8.8	16.2	11.6	9.6	7	28.5	20.5	16.8	12.2	22.1	15.9	13	9.5
160	11.5	8.3	6.8	4.9	9.1	6.6	5.4	3.9	16.3	11.7	9.6	7	13	9.3	7.7	5.6	23.2	16.7	13.7	10	18	12.9	10.6	7.7

SIZE	HC-800								HC-900								HC-1000							
	960				720				960				720				960				720			
	Duty Ratio	I	II	III	IV	I	II	III	IV	I	II	III	IV	I	II	III	IV	I	II	III	IV	I	II	III
31.5	137	98.4	80.8	59	107	76.8	63.1	46	196	141	116	84.3	153	110	90.3	65.8	270	194	159	116	211	151	124	90.7
40	112	80.4	66.1	48.2	87.4	62.8	51.6	37.6	162	116	95.6	69.7	126	90.5	74.3	54.2	221	159	130	95	172	123	101	74
50	93	66.8	54.9	40	72.5	52.1	42.8	31.2	135	97	79.7	58.1	105	75.4	62	45.2	184	132	109	79.1	144	103	85	62
63	78	56	46	33.5	61	43.8	36	26.2	110	79	65	47.3	86	61.7	50.7	37	152	109	89.7	65.4	119	85.4	70.2	51.2
80	63	45.2	37.2	27.1	49	35.2	29	21.1	88	63.2	51.9	37.8	68.6	49.3	40.5	29.5	123	88.3	72.6	38	96	69	56.6	41.3
90	56	40.2	33	24.1	43.7	31.4	25.8	18.8	81	58.2	47.8	34.8	63.2	45.4	37.3	27.2	110	79	65	47.3	86	61.7	50.7	37
100	51	36.6	30.1	22	40	28.7	23.6	17.2	74	53.1	43.7	31.8	57.7	41.4	34	24.7	100	71.8	59	43	78	56	46	33.5
125	42	30.2	24.8	18.1	32.8	23.6	19.4	14.1	59	42.4	34.8	25.4	46	33	27.1	19.8	83	59.6	49	35.7	64.7	46.5	38.2	27.8
160	33	23.7	19.5	14.2	25.7	18.5	15.2	11.1	48	34.5	28.3	20.6	37.4	26.9	22.1	16.1	66	47.4	39	28.4	51.5	37	30.4	22.1

SIZE	HC-1120								HC-1250							
	960				720				960				720			
	Duty Ratio	I	II	III	IV	I	II	III	IV	I	II	III	IV	I	II	III
31.5	380	273	224	163	300	215	177	129	529	380	312	227	418	300	247	180
40	311	223	183	134	246	177	145	106	431	309	254	185	340	244	201	146
50	260	187	153	112	205	147	121	88.2	364	261	215	157	288	207	170	124
63	213	153	126	91.6	168	121	99	72.2	300	215	177	129	237	170	140	102
80	172	123	101	74	136	97.6	80	58.5	246	177	145	106	194	139	114	83.4
90	157	113	92.6	67.5	124	89	73.2	53.3	221	159	130	95	175	126	103	75.3
100	142	102	83.8	61.1	112	80.4	66.1	48.2	197	141	116	84.7	156	112	92	67.1
125	115	82.6	67.9	49.5	91	65.3	53.7	39.1	162	116	95.6	69.7	128	92	75.5	55
160	93	66.8	54.9	40	73.5	52.8	43.4	31.6	130	93.3	76.7	56	103	74	60.8	44.3

VERTICAL TRIPLE STAGE

VERTICAL TYPE 'VC'

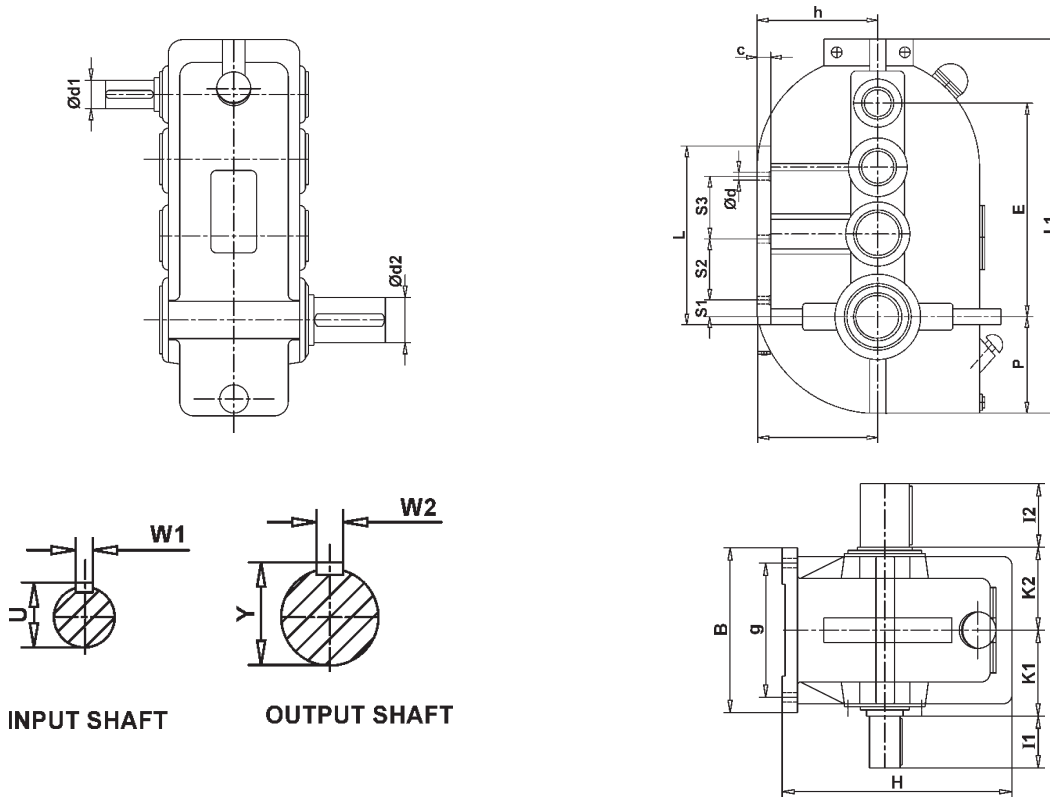

PRINCIPAL DIMENSIONS in mm

SIZE	Housing dimension								Foundation hole details							Weight (Approx kg)
	VC	E	L	B	H	h	L ₁	P	T	S ₁	S ₂	S ₃	g	d	c	
280	280	240	176	272	130	483	113	128	50	-	140	140	14	20	4	117
320	320	270	190	295	140	543	123	138	60	-	150	150	17	20	4	150
350	350	280	225	320	150	595	135	148	60	-	160	185	17	20	4	165
400	400	330	230	376	178	680	170	176	45	110	120	188	18	20	6	190
475	475	482	270	475	225	815	205	221	50	80	200	215	18	25	8	225
550	550	560	285	488	235	880	215	230	50	70	320	245	18	30	8	278
600	600	625	350	570	250	975	240	-	50	70	375	305	18	35	8	324

Size	Input Shaft			Output Shaft			Input Key		Output Key	
VC	d ₁	I ₁	K ₁	d ₂	I ₂	K ₂	W ₁	U	W ₂	Y
280	24	50	110	40	55	115	8	27	12	43
320	28	65	120	48	70	125	8	31	14	51.5
350	28	65	140	48	70	145	8	31	14	51.5
400	30	70	145	55	90	150	8	33	16	59
475	38	105	160	65	105	175	10	41	18	69
550	38	105	195	80	105	187	10	41	22	85
600	38	105	210	80	120	215	10	41	22	85



H.P. Rating of Vertical Triple Stage Gear Boxes VC

VC-280										VC-320								VC-350								
RPM	960				720				Duty Ratio	960				720				Duty Ratio	960				720			
Duty Ratio	I	II	III	IV	I	II	III	IV		I	II	III	IV	I	II	III	IV		I	II	III	IV	I	II	III	IV
14.85	5.8	4.2	3.4	2.5	4.5	3.2	2.7	1.9	14.26	7	5	3.9	3	5.7	4	3.3	2.5	10.69	10.7	7.5	5.9	4.7	9.2	6.4	5.1	4
20.62	4.7	3.4	2.8	2	3.6	2.6	2.1	1.5	17.0	5.9	4.2	3.3	2.5	4.8	3.4	2.7	2	14.67	8.1	5.7	4.5	3.6	6.9	4.8	3.8	3
24.0	4	2.9	2.4	1.7	3.1	2.2	1.8	1.3	25.28	4	2.8	2.2	1.7	3.2	2.2	1.8	1.4	30.56	4.1	2.9	2.3	1.8	3.4	2.4	1.9	1.5
33.4	3.4	2.1	2	1.5	2.6	1.9	1.5	1.1	52.36	1.9	1.4	1	0.8	1.5	1	0.9	0.7	49.49	2.6	1.8	1.4	1.1	2.2	1.5	1.2	1

VC-400										VC-475								
RPM	960				720				Duty Ratio	RPM	960				720			
Duty Ratio	I	II	III	IV	I	II	III	IV		Duty Ratio	I	II	III	IV	I	II	III	IV
15.95	18.8	13.2	10.3	8.3	16.6	11.6	9.1	7.3	19.68	19.3	13.5	10.6	8.5	17.2	12.1	9.5	7.8	
21.0	16.7	11.7	9.2	7.3	14.1	9.9	7.8	6.2	29.06	16.4	11.5	9	7.2	14.4	10.1	7.9	6.3	
41.23	9	6.3	5	4	7.5	5.3	4.1	3.3	52.92	10.8	7.6	5.9	4.8	9.2	6.4	5.1	4	
85.39	4.4	3.1	2.4	1.9	3.6	2.5	2	1.6	109.61	5.6	3.9	3.1	2.5	4.7	3.3	2.6	2.1	

VC-550										VC-600								
RPM	960				720				Duty Ratio	RPM	960				720			
Duty Ratio	I	II	III	IV	I	II	III	IV		Duty Ratio	I	II	III	IV	I	II	III	IV
17.72	35.1	24.7	19.3	15.4	31.9	22.5	17.5	14	17.74	40	30.9	22.6	16.05	35.5	25.8	18.3	15	
32.90	25.6	18	14.1	11.3	21.6	15.2	11.9	9.5	32.93	30.5	21	14.32	12	23.39	16.07	12.1	10.5	
68.28	12.9	9.1	7.1	5.7	10.8	7.6	5.9	4.8	68.02	14.5	11.5	7.7	6.5	13.3	8.75	6.17	5.5	
126.78	7.1	5	3.9	3.1	5.9	4.2	3.2	2.6	126.29	8.75	6	5.1	3.69	6	4.5	3.5	2.9	

OUR OTHER PRODUCTS :

CUSTOM BUILT GEAR UNITS
WORM & WORM GEARS
SLEWING RINGS
TIMING PULLEY
WORM REDUCTION GEAR UNITS
HARDENED GROUND GEARS
SPROCKETS
PLANETARY GEAR UNITS

INVOLUTE TOOLING CORPORATION

OFFICE: 13, JORBAGH, NEW DELHI - 110 003, INDIA, TEL: +91(011)24621453 FAX: +91(011) 24603609
WORKS: PLOT-65, SEC-27C, FARIDABAD - 121 003. INDIA, TEL: +91(0129) 4279000, 4279001
EMAIL : involute@vsnl.com URL: www.involutetools.com/ www.gears-reducers.com